

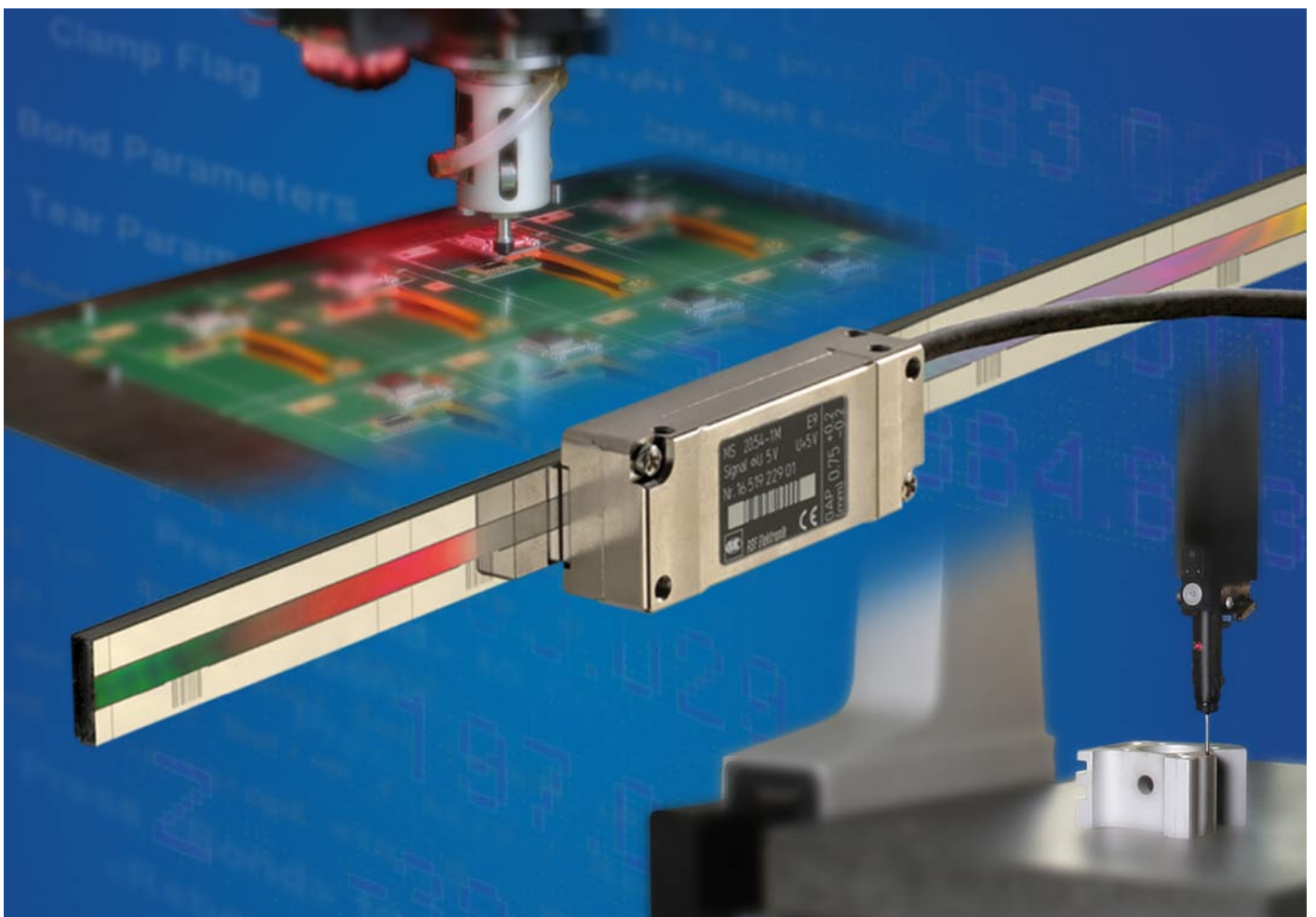

MS 20

Open Linear Encoder
with singlefield scanning



Special highlights:

- Small dimensions
- Easy mounting as a result of large mounting tolerances
- Contamination resistance
- High traversing speed
- Reference mark (accurate and repeatable from both traversing directions)
- Two independent switch signals (optical) for individual functions
- Integrated subdividing electronics in the encoder head for up to times 100 interpolation

Table of contents

	<u>Page</u>
Description of operating principles and design advantages	4
Scanning principle	5
Accuracy	6
Output signals.....	7
Switch-signal output	8
Cable and connector shielding, standard connector pin-outs.....	9
MS 20, MS 21 Technical data	10-11
MS 20 MK	12
MS 20 MA, MS 20 MS	13
MS 20 MP	14
MS 20 MT	15
MS 20 GK	16
MS 20 GA	17
MS 21 MK	18
MS 21 MA, MS 21 MS	19
MS 21 GK	20
MS 21 GA.....	21
Accessories: Electronic signal test/set-up boxes	
PG	22
Other RSF products.....	23
Branch offices.....	24

Term-explanation

Grating Pitch (Interval)

A grating is a continuous series of lines and spaces printed on the scale. The width of one line and one space is called the pitch (sometimes referred to as the interval) of the grating. The lines and spaces are accurately placed on the scale.

Signal Period

When scanning the grating, the encoder head produces sinusoidal signals with a period equal to the grating pitch.

Interpolation

The sinusoidal signal period can be electronically divided into equal parts. The interpolation circuitry generates a square wave edge for each division.

Reference Pulse (Reference Mark)

There is an additional track of marks printed next to the grating to allow a user to find an absolute position along the length of the scale. A one increment wide signal is generated when the encoder head passes the reference mark on the scale. This is called a "true" reference mark since it is repeatable in both directions. Subsequent electronics use this pulse to assign a preset value to the absolute reference mark position.

Error Signal

This signal appears when a malfunctioning encoder generates faulty scanning signals.

Measuring Step (Resolution)

This is the smallest digital counting step produced by an encoder.

Accuracy

This is a fundamental characteristic of a measuring system. It is the maximum permissible deviation of a measured value to a reference value. Accuracy is stated in (\pm) microns per meter of travel. Scales are specified with an accuracy grade (e.g. $\pm 5\mu\text{m}/\text{m}$).

Abbe Error

Measuring error due to lateral distance between the measuring system and the machine guideway.

Yaw Angle , Pitch Angle, Roll Angle, Lateral, Airgap

Mounting tolerances of the encoder head relative to the scale.

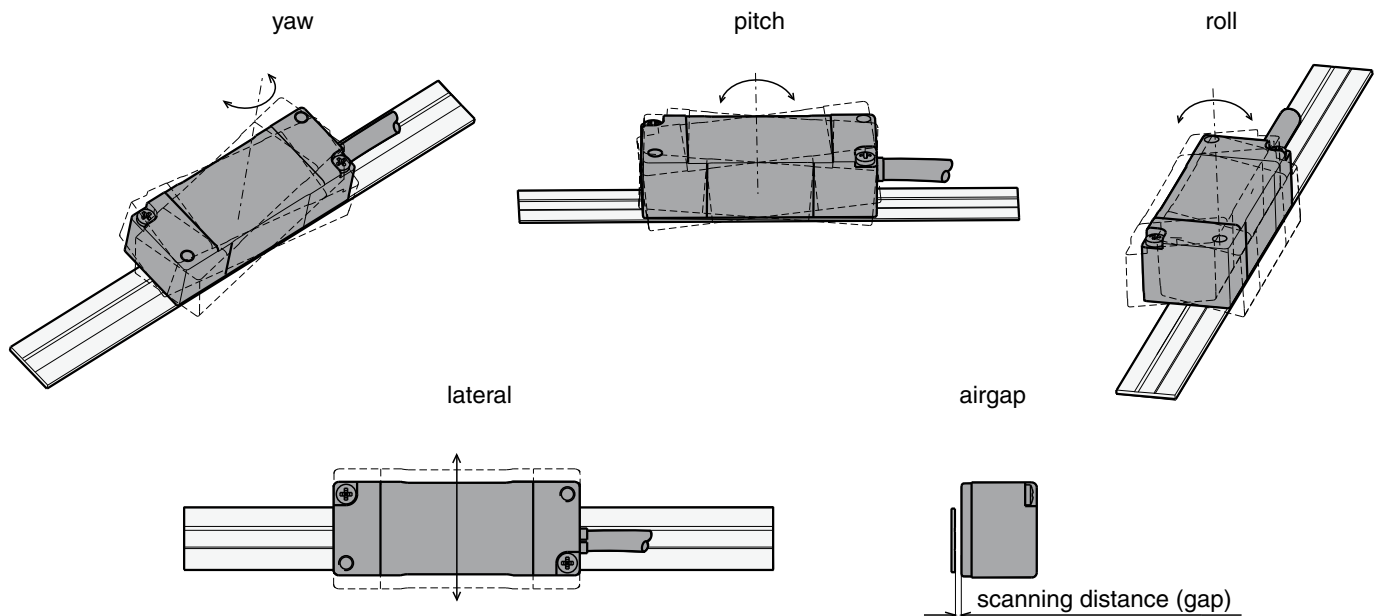

What design characteristics do you require in an Open Linear Encoder?

- Contamination resistance
- Immunity against aging and temperature changes
- High resolution
- High speed
- Large mounting tolerances
- Small dimensions

The new MS 20, MS 21 meets all these requirements!

The trend today in motion control applications is for Open Linear Encoder systems.

This is driven by steadily increasing demands for

- Higher traversing speed
- Higher operating cycles
- Lower mechanical backlash
- Zero frictional force induced by the encoder.

Only open, non-contact encoders fulfill all these requirements.

For special requirements like closed loop, speed control, highest accuracy and others it is important to minimize the interpolation errors.

Historically, the small grating periods used had the disadvantages of smaller mounting gaps and very tight overall mounting tolerances. The MS 20, MS 21 encoders' 40 µm grating period minimizes interpolation errors but can be mounted with a large gap and liberal mounting tolerances.

A drawback of many open Linear Encoders is their sensitivity to dirt and contamination on the scale.

The MS 20, MS 21 encoders' unique optical design minimizes the effect of dirt and contamination normally associated with the Open Linear Encoders.

The MS 20, MS 21 utilizes a unique scanning principle which allows high traversing speeds (up to 10 m/s), large mounting tolerances and contamination on the scale.

Reference marks, accurate and repeatable from both traversing directions, are standard.

Version MS 21: The position of the reference mark can be selected by the customer.

A wide range of interpolation electronics, integrated into the encoder head, enables resolutions from 10 µm to 100 nm. Squarewave signals, single ended, or via Line Driver RS 422, are provided at the output of the encoder head.

Units with sinusoidal output, 1Vpp, are also available.

Two end of travel optical switch signals are available directly out of the reader head. The end of travel signal locations can be easily set by the user.

Due to recent advancements in technology, all of these benefits are now available in a small package design.

Reading head gap (mm) - vs. - Change in signal amplitude (%)

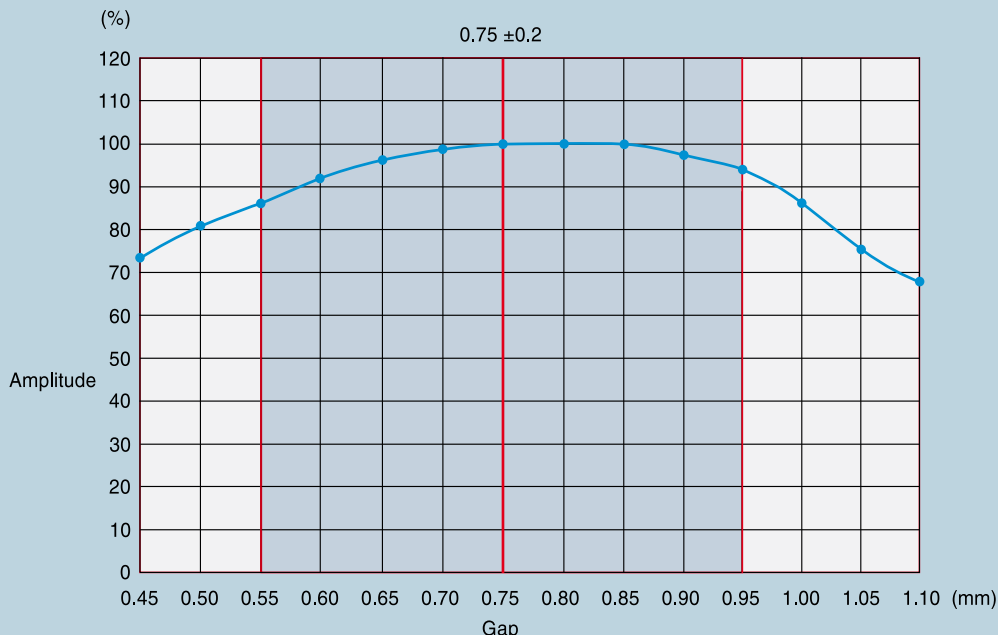

Scanning principle

The MS 20, MS 21 incremental Linear Encoders work with the imaging, photoelectric measuring principle and a **singlefield reflective scanning** method.

A scale graduation pattern on a steel tape (with gold grating) or a glass scale (with chrome grating) with 40 µm grating pitch is used. The light from an infrared LED with a small light emitting surface is collimated parallel by a condenser lens and directed through the scanning reticle to the scale. When the scale is moved relative to the encoder head, the light is modulated by the scale gratings and produces a periodic intensity signal that is converted into electrical signals by photo elements back in the encoder head.

The scanning reticle is designed to allow for a large mounting gap and liberal mounting tolerances. This system is insensitive to waviness of the steel tape due to poor mounting conditions. Any minor differences in the grating period of the scale or the scanning reticle will not cause a measuring problem due to the large continuous pattern reflected onto the structured sensor.

This sensor consists of multiple photo elements connected in a pattern to generate four sinusoidal signals, each shifted by 90°. All four signals are generated from one scanning field and all four signals are equally influenced by any contamination simultaneously. When all four signals are influenced at the same time by the same amount, interpolation error is eliminated.

Scanning principle

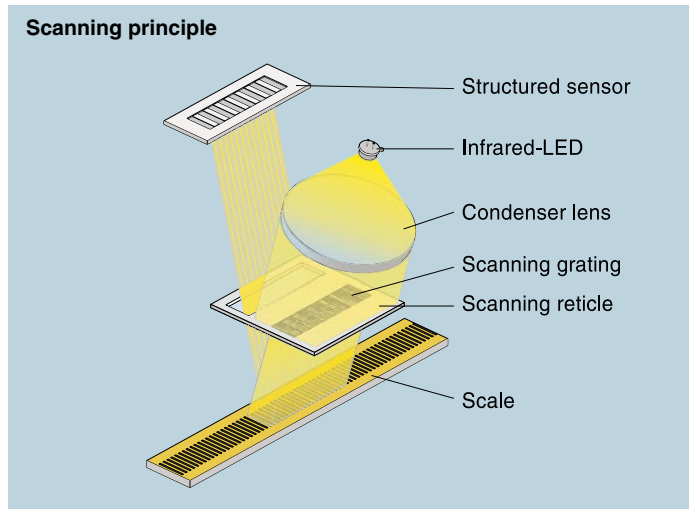

Effect of contamination on the quality and size of the measuring signal

Clean steel tape scale - optimal condition

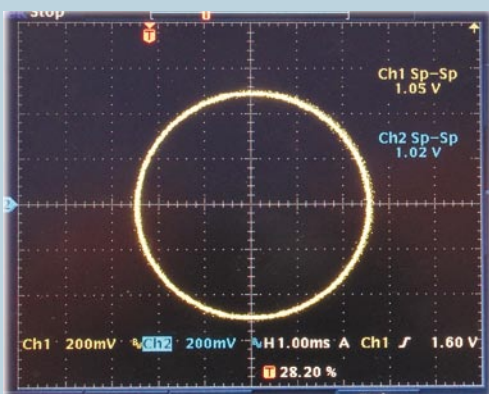
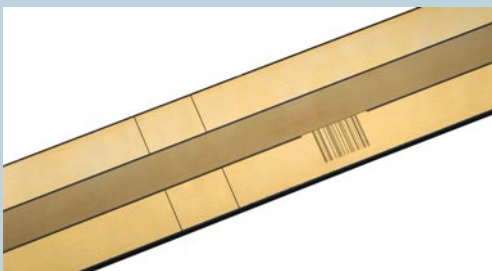

Contaminated steel tape scale - unfavorable condition

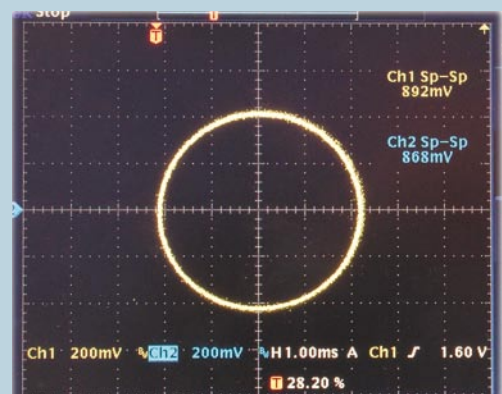
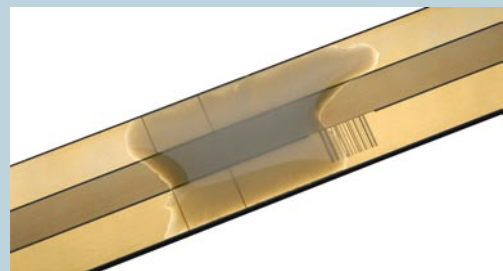

Accuracy

The accuracy of the Linear Encoder is classified with a "± tolerance" in µm/m (e.g. ± 5 µm/m).

The accuracy and tolerance apply to any meter within the measuring length.
For measuring lengths less than 1000 mm, the accuracy specification applies over the measuring length.

For best system accuracy, the encoder should be mounted near a machine guideway and as parallel to the motion as possible.

Example of a typical calibration chart for a MS 20 scale tape.



RSF Elektronik
Ges.m.b.H.

Elektronische Längenmessgeräte
Digitale Positionsanzeigen
Industrie-Elektronik, Präzisionsteilungen

RSF Elektronik Ges.m.b.H.
A-5121 Tarsdorf

MESSPROTOKOLL • CALIBRATION CHART • ETALONNAGE

Gerätetyp
Type
MS 20.X4 MO

Serien-Nr.
Serial-No.
013038100

Änderungsindex
Change-Index
Indice de changement

Auftrag
Acknowledgement
Commande

Position-Nr.
Position-No.
Position-No.

**Zertifiziert nach
DIN EN ISO 9001**

Dieses RSF-Längenmesssystem wurde unter strengen Auflagen modernster Qualitätsrichtlinien hergestellt und geprüft.

Unter folgenden messtechnischen Bedingungen haben wir das Längenmesssystem auf dessen Genauigkeit vermessen und protokolliert:

- Bezugstemperatur 20°C
- Luftfeuchtigkeit 50%
- Messmaschine mit luftgelagerter Führung
- HP-Laserinterferometer Typ 5527A

Systemdaten:

Messlänge: 720mm

Maßstabintervall: 40µm

Ausgangssignal: LD

Versorgungsspannung: 5V

Kabelausgang: rechts

Referenzmarken-Position:

Referenzmarken-Code: 99

Systemgenauigkeit: ± 15µm/m

Datenblatt:

Pos. (mm)	Error (µm)	-15	-10	-5	0	5	10	15
0	+0.92							
10	+0.65							
20	+0.39							
30	+0.35							
40	+0.46							
50	+0.21							
60	+0.25							
70	+0.14							
80	+0.07							
90	+0.08							
100	-0.00							
110	-0.00							
120	-0.47							
130	-0.52							
140	-0.68							
150	-0.76							
160	-0.91							
170	-1.09							
180	-1.01							
190	-1.01							
200	-1.06							
210	-1.29							
220	-1.40							
230	-1.47							
240	-1.49							
250	-1.52							
260	-1.55							
270	-1.68							
280	-1.49							
290	-1.45							
300	-1.50							
310	-1.37							
320	-1.33							
330	-1.37							
340	-1.38							
350	-1.41							
360	-1.51							
370	-1.28							
380	-1.21							
390	-0.98							
400	-0.88							
410	-0.78							
420	-0.62							
430	-0.46							
440	-0.46							
450	-0.55							
460	-0.41							
470	-0.18							
480	-0.17							
490	+0.01							
500	-0.12							
510	-0.17							
520	-0.01							
530	-0.07							
540	-0.14							
550	+0.01							
560	+0.24							
570	+0.38							
580	+0.48							
590	+0.81							
600	+0.91							
610	+0.77							
620	+0.74							
630	+0.91							
640	+0.23							
650	+1.05							
660	+1.17							
670	+1.26							
680	+1.39							
690	+1.47							
700	+1.56							
710	+1.62							
720	+1.68							

Max. Abweichung	±1.68 µm	max. total error	±1.68 µm	Default max	±1.68 µm
-----------------	----------	------------------	----------	-------------	----------

Prüfer/checker/contrôleur : STEFLITSCH DATUM/DATE/DATE : 2005.03.29 Zeit/Time/Heure : 14:04

RSF Elektronik Ges.m.b.H. A-5121 Tarsdorf, +43 (0)8278/8192-0, e-mail: info@rsf.at, www.rsf.at

Output signals

Sinusoidal voltage signals (drawing shows "positive counting direction")
Two sinusoidal voltage signals A1 and A2 and one reference mark signal (all with inverted signals).

- Power supply: +5V ±5%, max. 130 mA (unloaded)
- Reference voltage of the output signals: V+/2 (approx. 2.5 V)
- Track signals (differential voltage A1 to A1 resp. A2 to A2):
Phaseshift 90° ±10° el.
- Signal amplitude 0.6 Vpp to 1.2 Vpp
- typ. 1 Vpp with terminating impedance $Z_0 = 120 \Omega$
- Reference Mark (differential voltage RI to RI):
El. position typical 135° (referenced to A1)
- El. width typical 360°
- Useable component 0.2 up to 0.85 V, typical 0.5 V
- with terminating impedance $Z_0 = 120 \Omega$

Advantage:
- High traversing speed with long cable lengths possible

Square wave signals (drawing shows "positive counting direction")
With a Schmitt-Trigger (for times 1) or interpolation electronics (for times 5, -10, -20, -25, -50 or -100) the photoelement output signals are converted into two square wave signals that have a phase shift of 90°. Output signals either can be single ended or Line Driver differential (RS 422). For measuring systems with single ended output signals the max. cable length is 10 m, including extension cable. One measuring step reflects the measuring distance between two edges of the square wave signals.

The controls/DRO's must be able to detect each edge of the square wave signals. The minimum edge separation a_{min} is listed in the technical data and refers to a measurement at the output of the interpolator (inside the scanning head). Propagation-time differences in the Line Driver, the cable and the Line Receiver reduce the edge separation.

- Propagation-time differences:
- Line Driver: max. 10 ns
 - Cable: 0.2 ns per meter
 - Line Receiver: max. 10 ns referred to the recommended Line Receiver circuit

To prevent counting errors, the controls/DRO's must be able to process the resulting edge separation.

Example:
 $a_{min} = 100 \text{ ns}$, 10 m cable
The control/DRO must be able to detect $100\text{ns} - 10\text{ns} - 10 \times 0.2\text{ns} - 10\text{ns} = 78\text{ns}$

Power supply: +5 V ±5%, max. 165 mA (unloaded)

Advantage:
- Noise immune signals
- No further subdividing electronics necessary

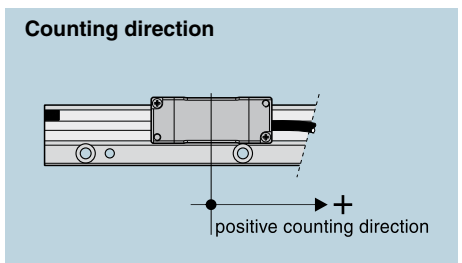
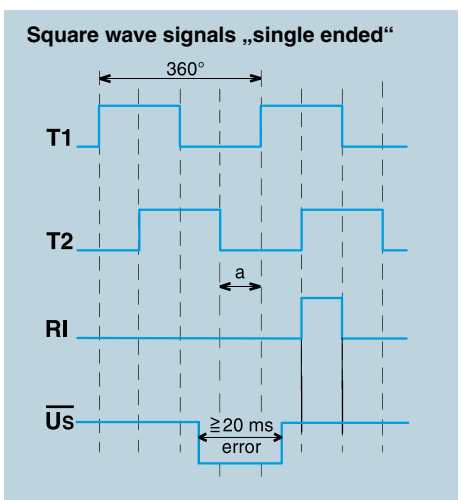
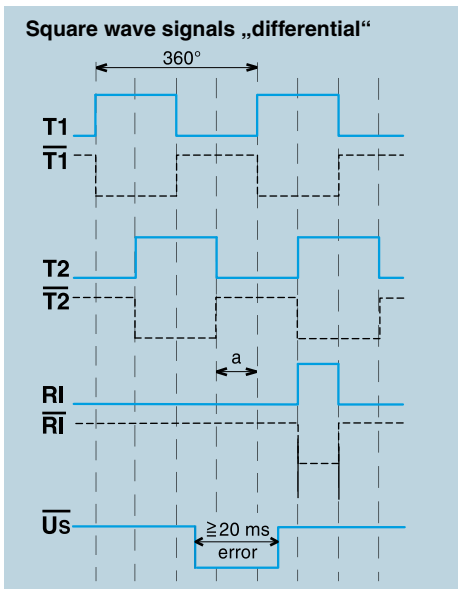
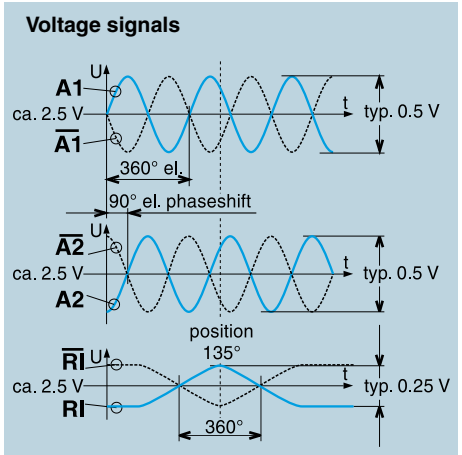
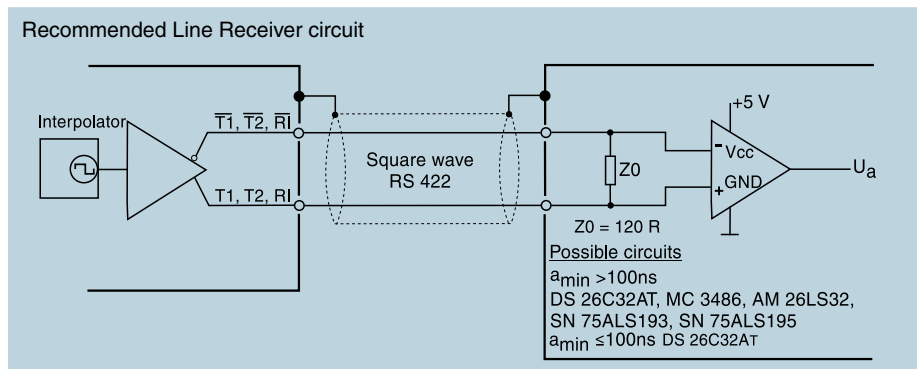

Switch-signal output

For individual special functions there are two additional switch tracks on the glass scale/ metal tape .

The switching point position can be chosen by the user by placing self adhesive covering tapes.

With the MS 21 version there is just one switch signal available.

The second track of this version is used to select the reference mark.

This feature makes the selection of the reference mark position, by the user, very easy.

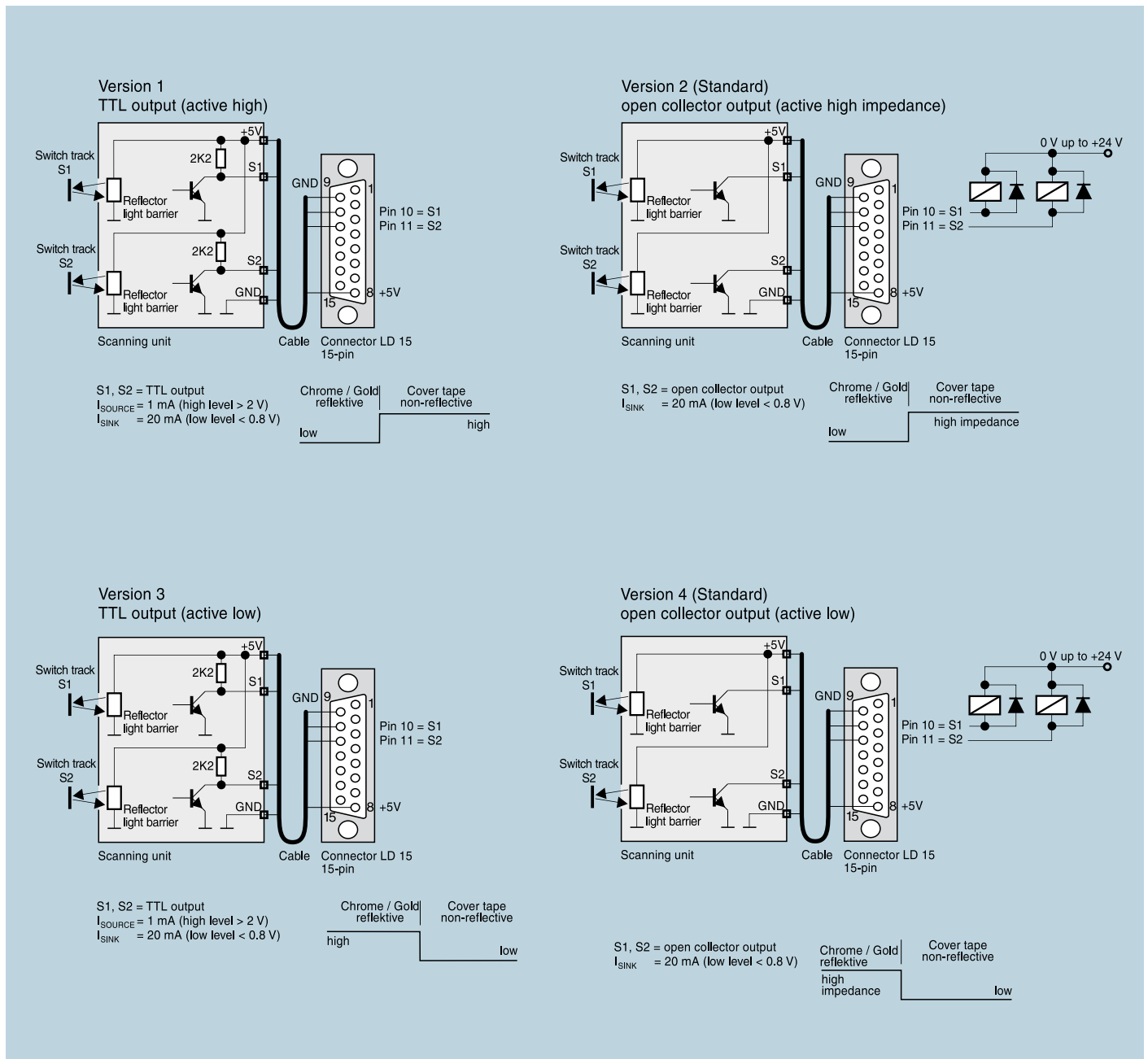

Cable and connector shielding, standard connector pin outs

Cable type is determined by the application. The standard is a 3 meter cable with a PUR jacket material. Cables for use in vacuum applications to 10^{-7} torr are also available upon request.

Square wave signals Sinusoidal voltage signals

Single shielded cable, standard, \varnothing 4.3 mm
permissible bending radii: fixed mounting 25 mm, continuous flexing 45 mm
(typical 50×10^6 bending cycles)
The connector must be connected to protective ground

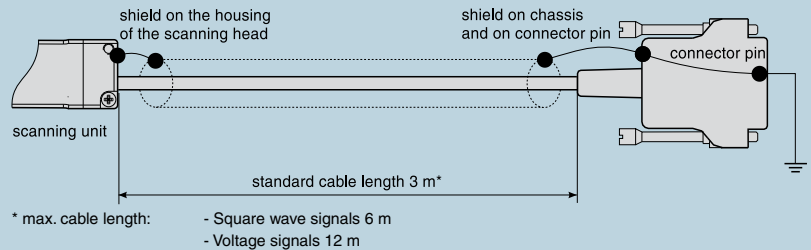

Connector LD15 15-pin

PIN	1	2	3	4	5	6	7	8	9	10	11	12	13	14	15
Square wave signals via Line Driver	Test	GND	$\overline{U_s}$	\overline{RI}	$\overline{T_2}$	$\overline{T_1}$	+5 V	+5 V	GND	S1*	S2*	RI	T2	T1	Shield

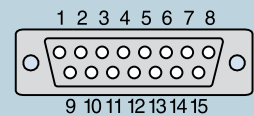

PIN	1	2	3	4	5	6	7	8	9	10	11	12	13	14	15
Voltage signals	nc	GND	nc	\overline{RI}	$\overline{A_2}$	$\overline{A_1}$	+5 V	+5 V	GND	S1*	S2*	RI	A2	A1	Shield

PIN outs
(View on pins)

- Test = **analog signal switch-over for setup**
By applying +5V to the test pin, the scanning signals (analog) are switched to the output connector.
- MS 20: S1, S2 = Switch signals
MS 21: S1 = Conditionally possible for switch signal
S2 = Switch signal
- * Version without switch signals (Version 0) = nc
- The shield is connected with the chassis

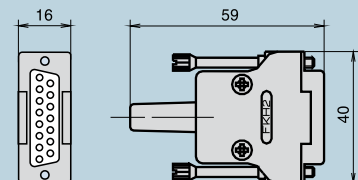

MS 20, MS 21 Technical data

Features:

- Small dimensions
- Easy mounting as a result of large mounting tolerances
- High insensitivity to contamination through the use of singlefield scanning principles
- High traversing speed
- Integrated subdividing electronics in the encoder head for up to times 100 interpolation (before quadrature)
- True reference mark (accurate and repeatable from both traversing directions)
- MS 20: Two independent switch signals (optical) for individual functions
- MS 21: Position of reference mark can be selected by the customer
- MS 21: One switch signal for special functions

Scanning unit: 40 µm grating pitch, system resolution from 10 µm to 0.1 µm

Scale model	System resolution	Grating pitch	Integrated interpolation	Max. velocity	Max. output frequency resp. Edge separation a_{min}
• Sinusoidal voltage signals					
MS 20.04 MS 21.04	depending on external interpolation	40 µm	--	10 m/s	250 kHz
• Square wave Line Driver signals with integrated Subdividing					
MS 20.24 MS 21.24	10 µm	40 µm	times 1	10 m/s	500 ns
MS 20.34 MS 21.34	5 µm	40 µm	times 2	10 m/s	250 ns
MS 20.64 MS 21.64	2 µm	40 µm	times 5	6 m/s	300 ns
MS 20.74 MS 21.74	1 µm	40 µm	times 10	3 m/s	300 ns
MS 20.44 MS 21.44	0.5 µm	40 µm	times 20	2.2 m/s	200 ns
MS 20.54 MS 21.54	0.4 µm	40 µm	times 25	1.8 m/s	200 ns
MS 20.84 MS 21.84	0.2 µm	40 µm	times 50	1.8 m/s	100 ns
MS 20.94 MS 21.94	0.1 µm	40 µm	times 100	0.9 m/s	100 ns

Scale unit: Grating carrier optional glass, glass ceramic* (ROBAX, ZERODUR), or steel

Mechanical features of the grating carrier	MS 20		MS 21	
	Grating carrier optional		Grating carrier optional	
	Glass scale	Steel tape scale	Glass scale	Steel tape scale
Grating pitch	40 µm	40 µm	40 µm	40 µm
Accuracy grades	±3, ±5 µm/m	±5, ±15 µm/m	±3, ±5 µm/m	±5, ±15 µm/m
Non-linearity	≤ ±1 µm/70 mm ≤ ±3 µm/1000 mm		≤ ±1 µm/70 mm ≤ ±3 µm/1000 mm	
Max. measuring length	3140 mm	9440 mm	3140 mm	9440 mm
Reference marks (RI) Standard: separated by distances of n x 50 mm	●	●	●	●
Reference marks (RI) at any location selected by customer	--	●	●	●
Reference marks (RI) distance coded up to measuring length 6240 mm possible	●	●	--	--
Position of reference mark selected by customer	--	--	●	●
Switch tracks	2	2	1	1
Grating scale only		MS 20.xx MO		MS 21.xx MO
Grating scale with adhesive tape	MS 20.xx GK	MS 20.xx MK	MS 21.xx GK	MS 21.xx MK
Grating scale in aluminum profile with adhesive tape	--	MS 20.xx MP	--	MS 21.xx MP*
Grating scale in aluminum profile, profile bolted	--	MS 20.xx MT	--	MS 21.xx MT*
Grating scale on aluminum profile, profile bolted	MS 20.xx GA	MS 20.xx MA	MS 21.xx GA	MS 21.xx MA
Grating scale on steel profile, profile bolted	--	MS 20.xx MS	--	MS 21.xx MS

● available
-- not available

* on request

Mounting-adjustment/Test: With electronic signal test/set-up box to optimize or check the mounting (Page 22)

Permissible vibration: 150 m/s² (40 bis 2000 Hz)

Permissible shock: 750 m/s² (8 ms)

Permissible temperature:

-20°C bis +70°C (storage), 0°C bis +50°C (operation)

Weight depending on scale version (approx.)

30 g/m (MO = Steel tape scale only)

35 g/m (MK = Steel tape scale without carrier) or

115 g/m (MP = Steel tape scale in aluminum carrier, carrier glued) + 20 g clamping element or

335 g/m (MT = Steel tape scale in the screwable aluminum carrier) + 20 g clamping element

550 g/m (MA = Steel tape scale onto screwable aluminum carrier)

1500 g/m (MS = Steel tape scale onto screwable steel carrier))

100 g/m (GK = Glass scale with adhesive tape)

650 g/m (GA = Glass scale onto screwable aluminum carrier)

+ 21 g (scanning head without cable)

MS 20.xx MO, MS 20.xx MK steel tape scale only or with adhesive tape
max. measuring length = 9440 mm

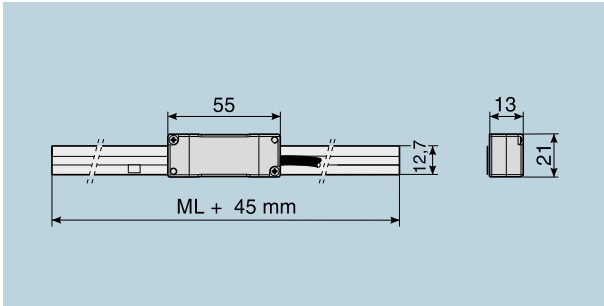

Dimensions, mounting tolerances, mounting possibilities:

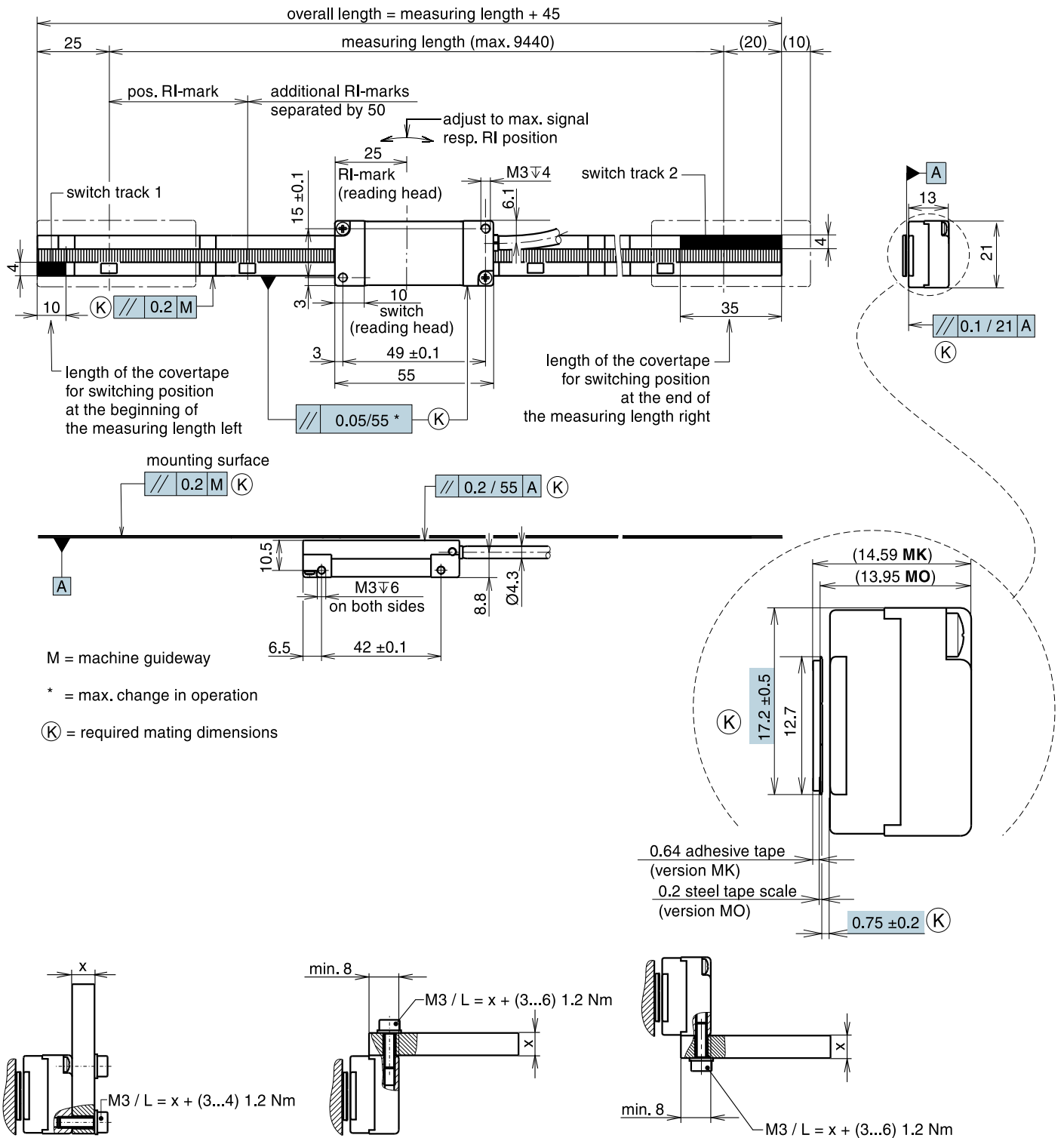

MS 20.xx MA steel tape scale on aluminum carrier, **MS 20.xx MS** steel tape scale on steel carrier, carrier bolted
 max. measuring length = 4340 mm max. measuring length = 3540 mm

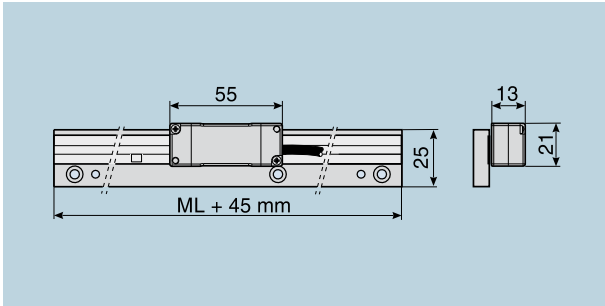

Dimensions, mounting tolerances, mounting possibilities:

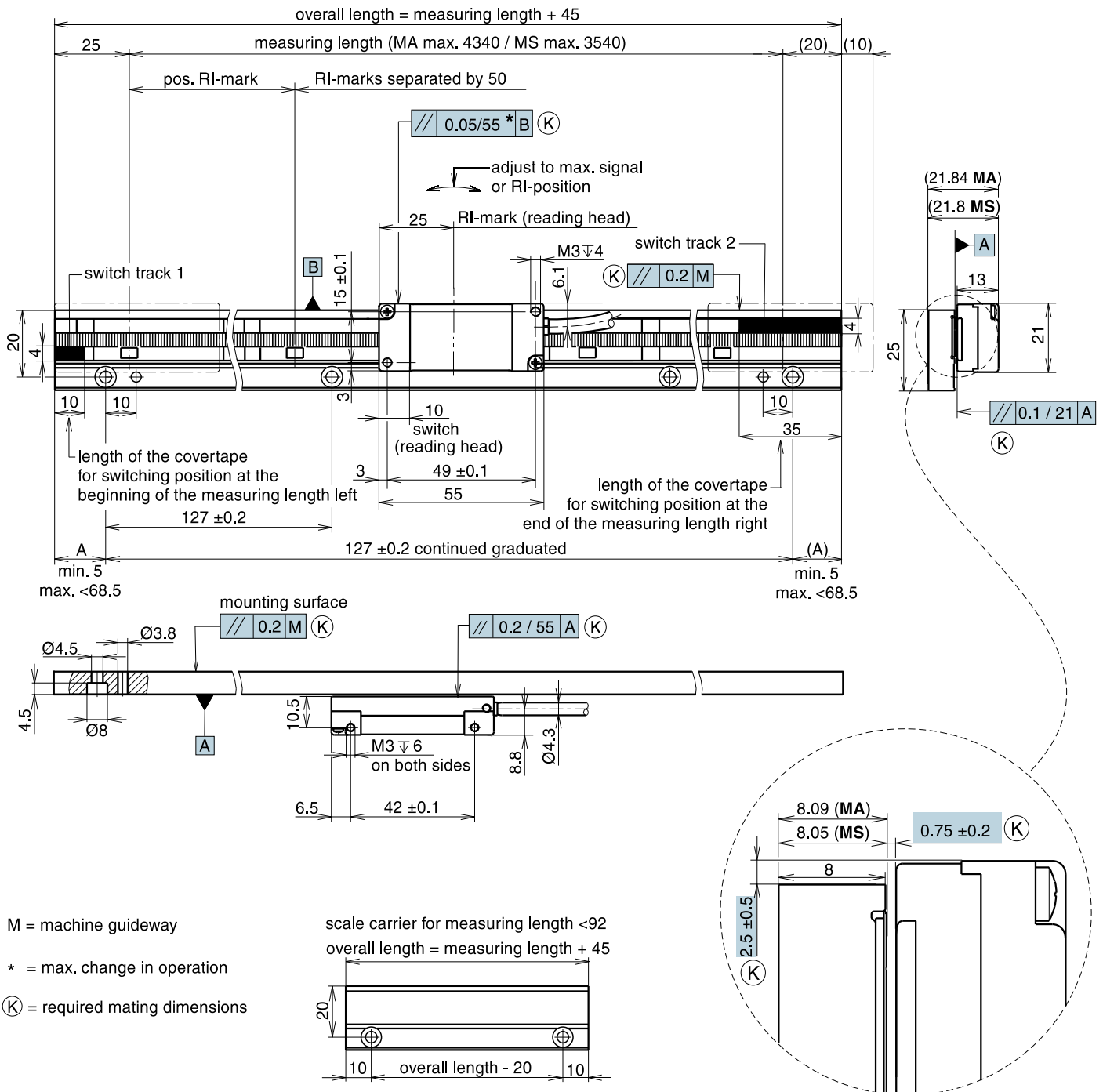

- M = machine guideway
- * = max. change in operation
- (K) = required mating dimensions

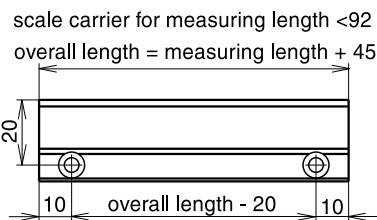

MS 20.xx MP steel tape scale in aluminum carrier with clamping element, carrier with adhesive tape
max. measuring length = 9440 mm

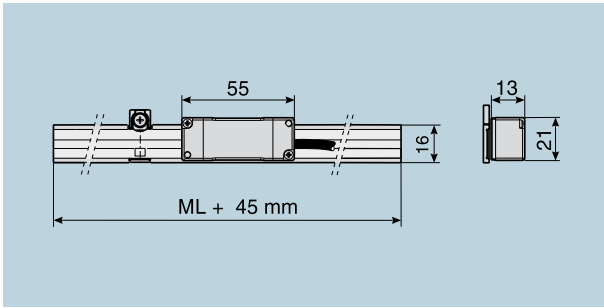

Dimensions, mounting tolerances, mounting possibilities:

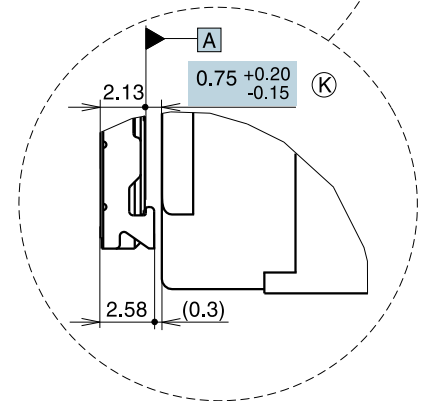
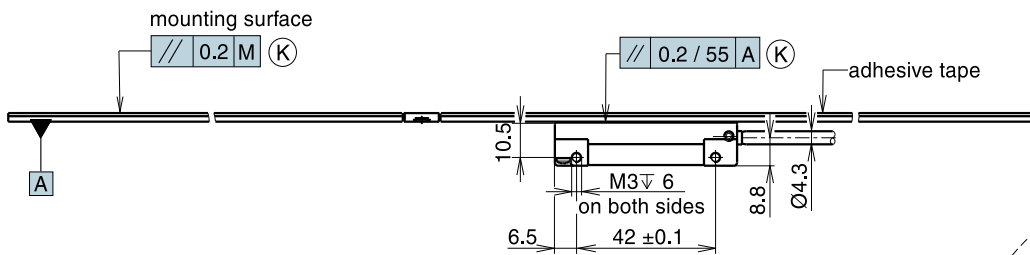
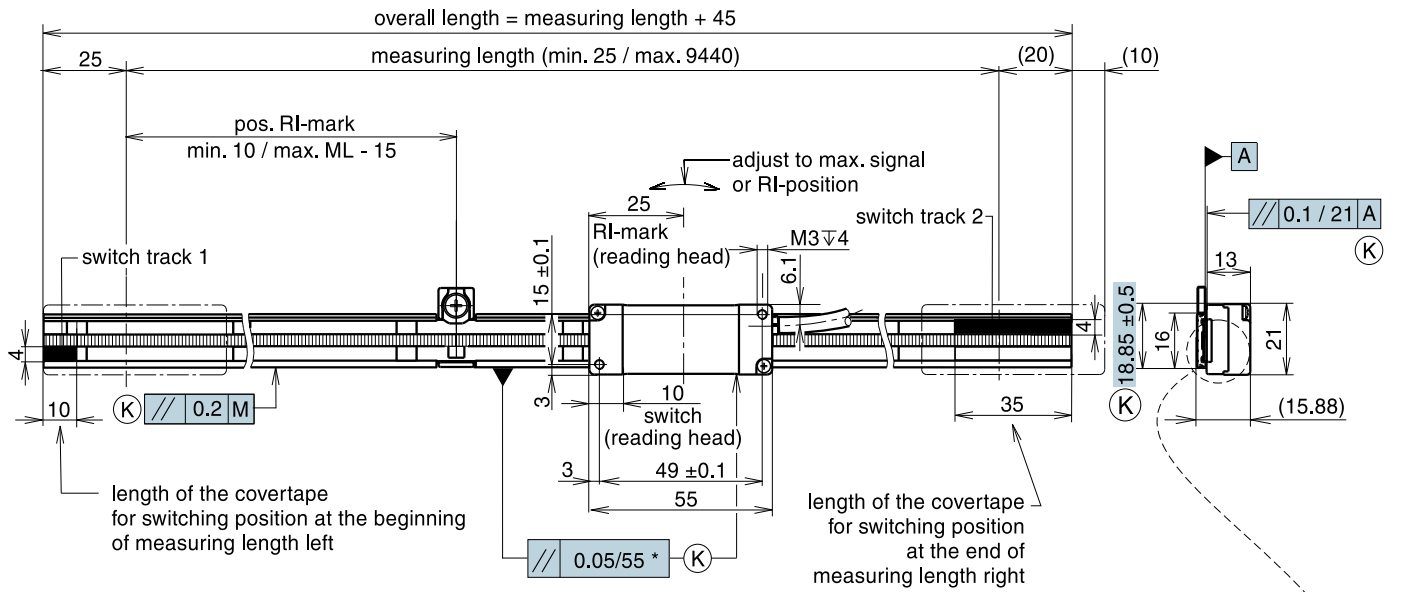

M = machine guideway
* = max. change in operation
Ⓚ = required mating dimensions

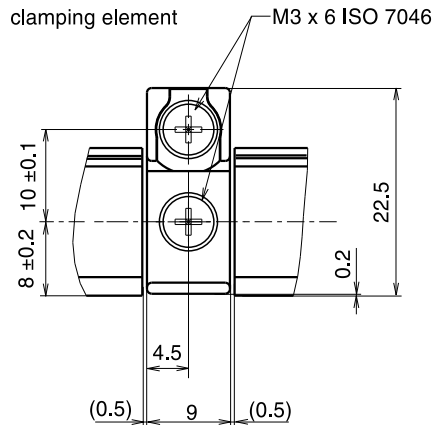

MS 20.xx MT steel tape scale in aluminum carrier with clamping element, carrier bolted
max. measuring length = 4240 mm

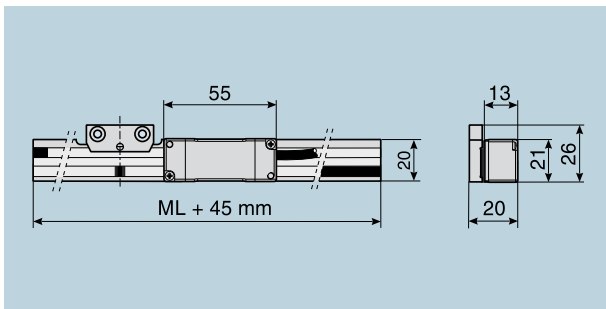

Dimensions, mounting tolerances, mounting possibilities:

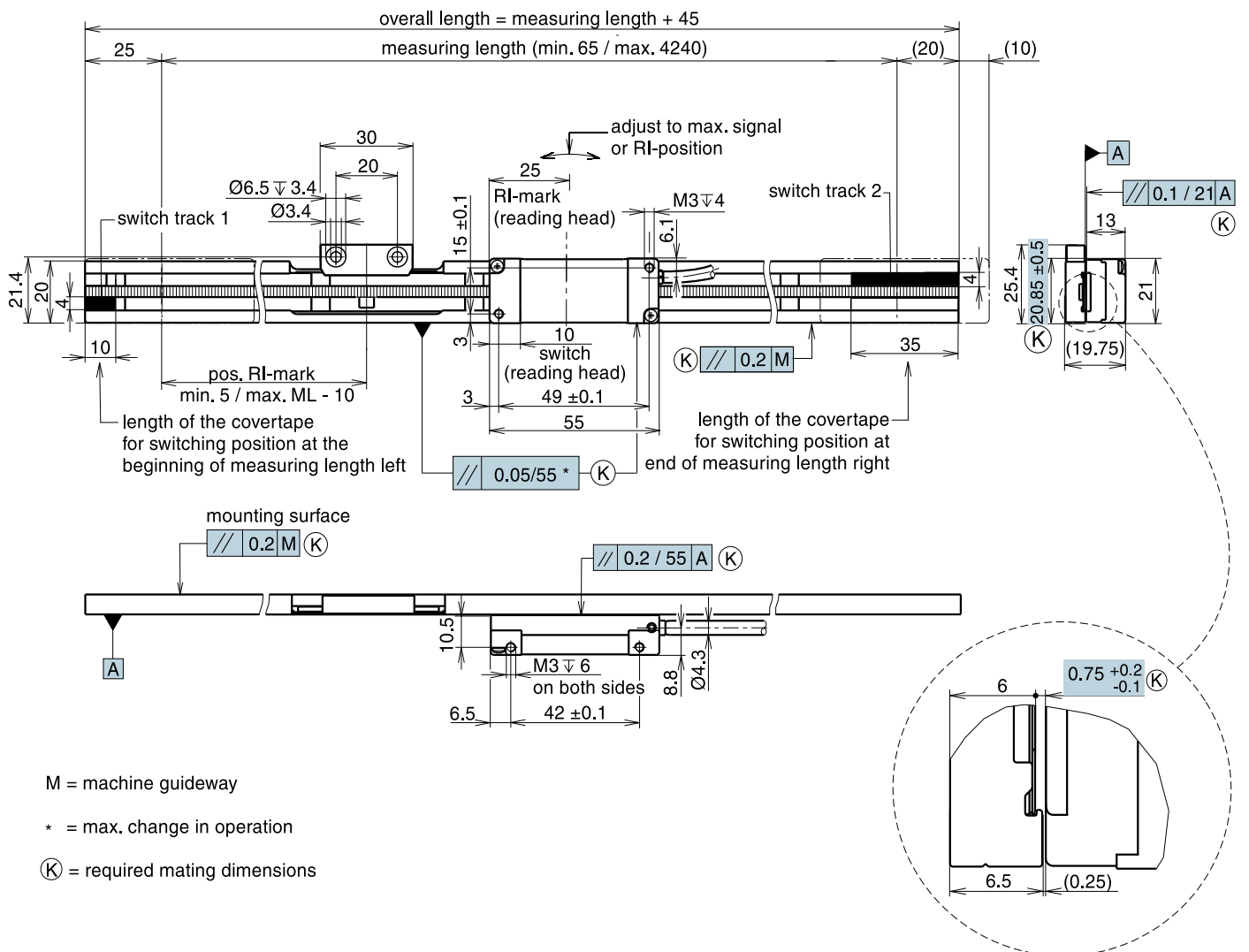

M = machine guideway

* = max. change in operation

Ⓚ = required mating dimensions

aluminum carrier

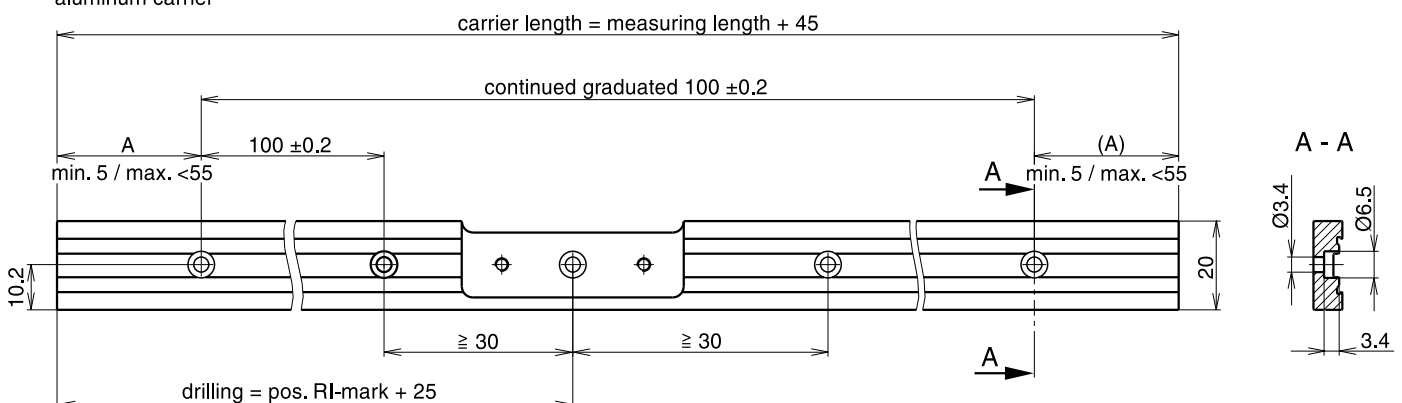

MS 20.xx GK glass scale with adhesive tape
max. measuring length = 3140 mm

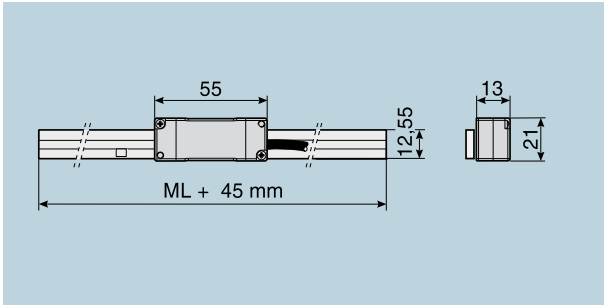

Dimensions, mounting tolerances, mounting possibilities:

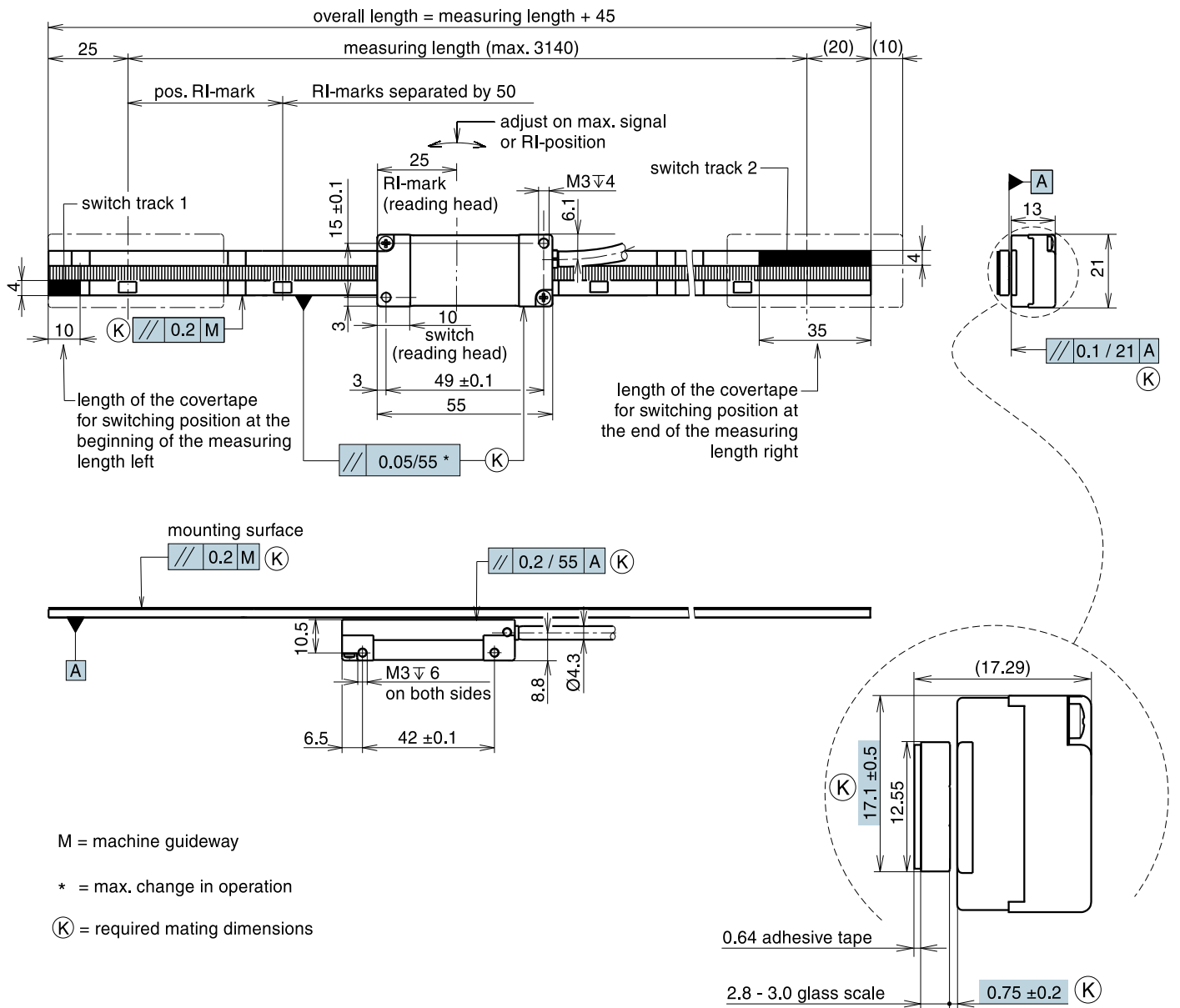

M = machine guideway

* = max. change in operation

(K) = required mating dimensions

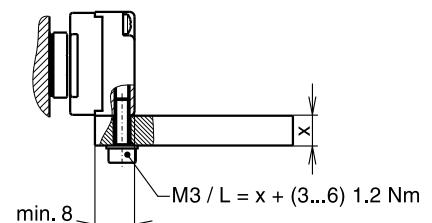
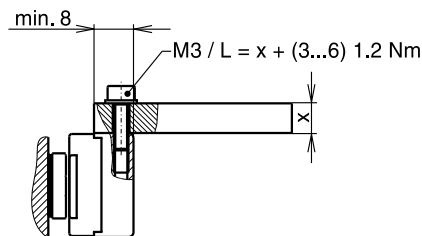
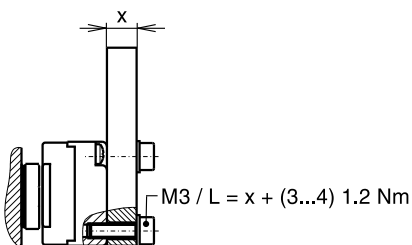

MS 20.xx GA glass scale on aluminum carrier, carrier bolted
max. measuring length = 3140 mm

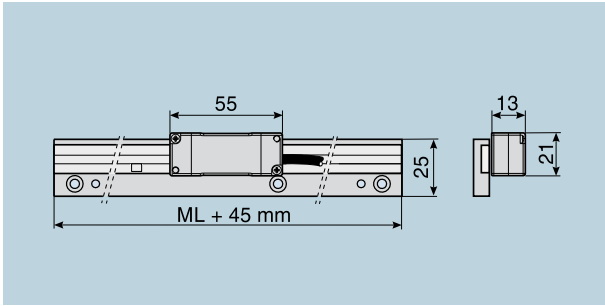

Dimensions, mounting tolerances, mounting possibilities:

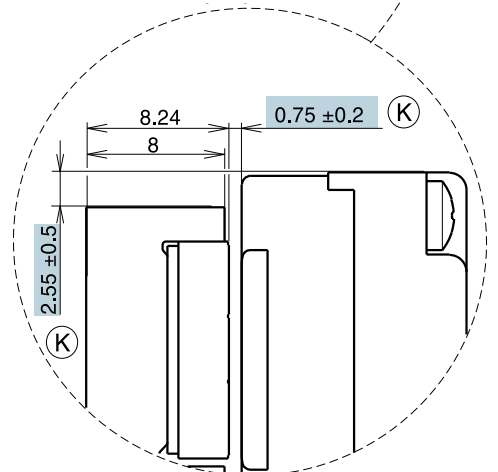
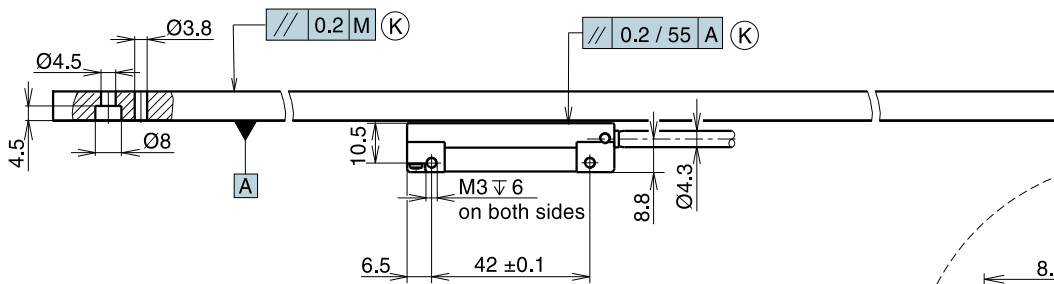
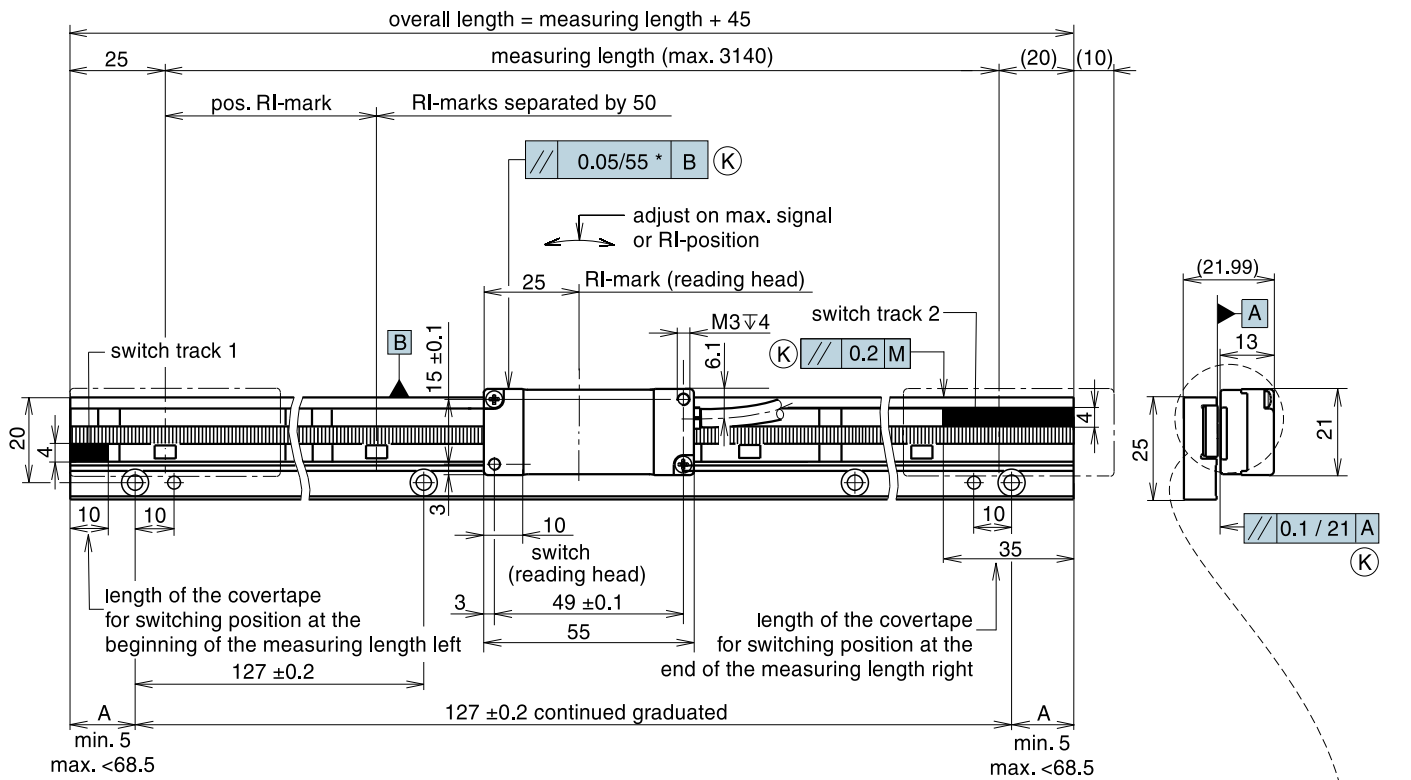

- M = machine guideway
- * = max. change in operation
- (K) = required mating dimensions

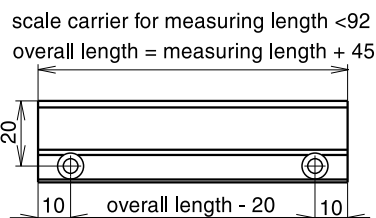

MS 21.xx MO, MS 21.xx MK steel tape scale only or with adhesive tape
max. measuring length = 9440 mm

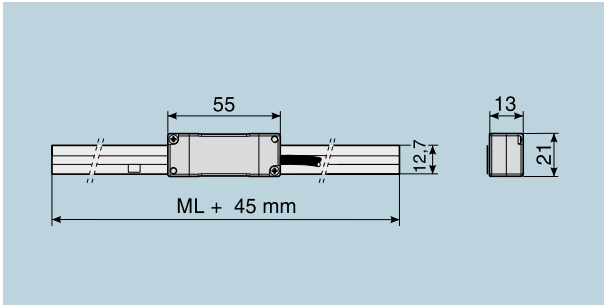

Dimensions, mounting tolerances, mounting possibilities:

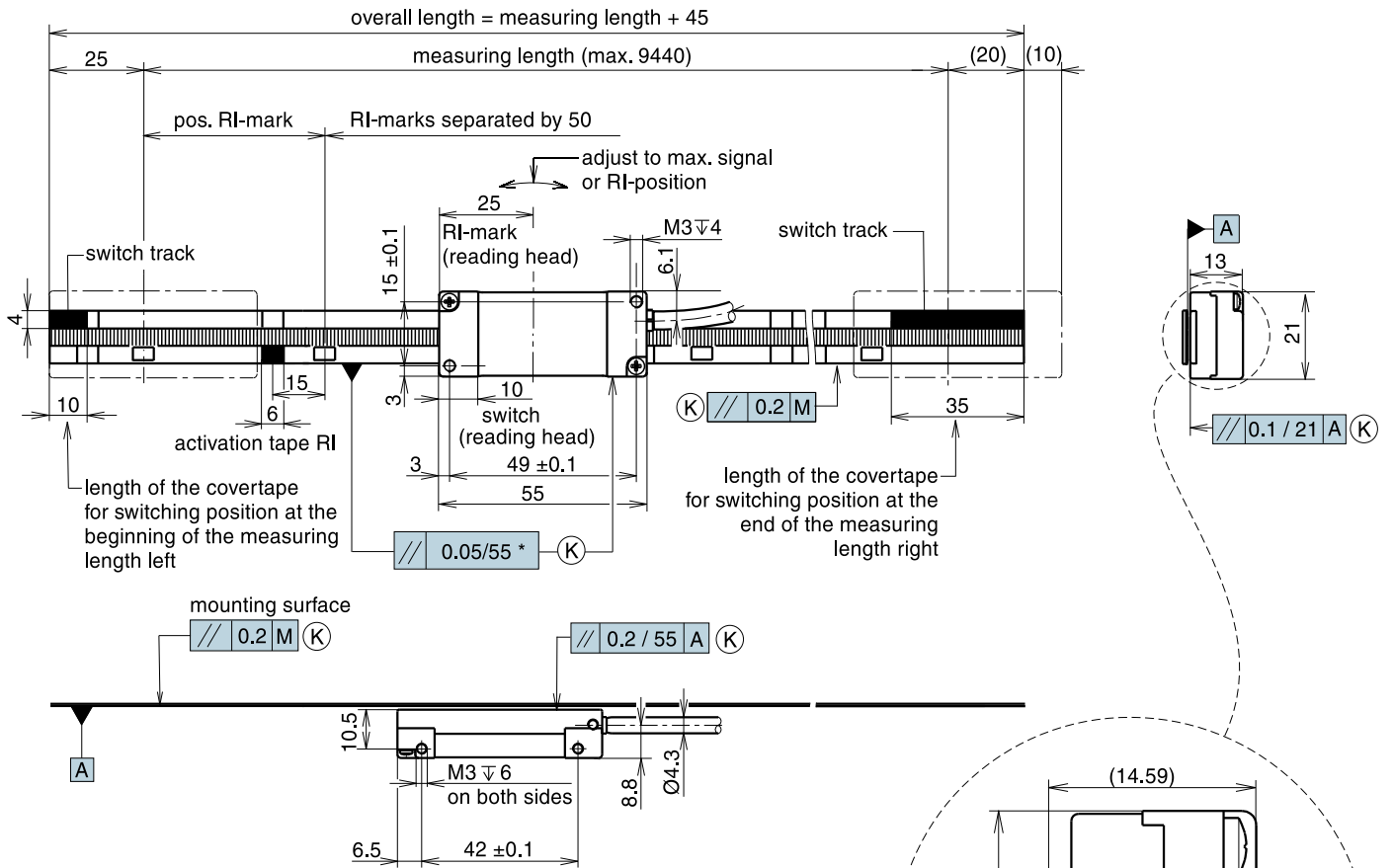

M = machine guideway

* = max. change in operation

(K) = required mating dimensions

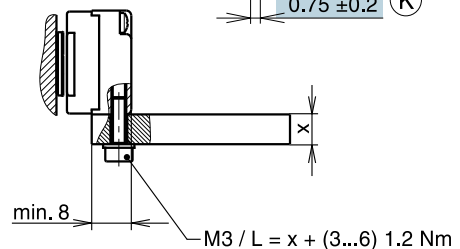
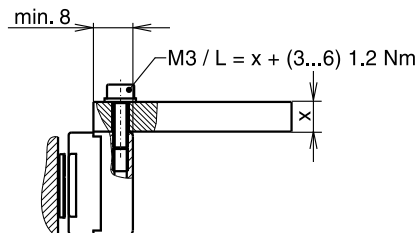
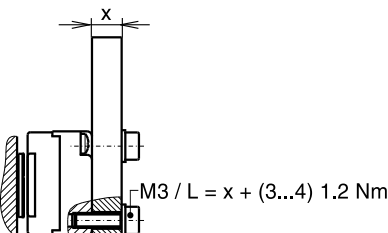

0.64 adhesive tape

0.2 steel tape scale

0.75 ± 0.2 (K)

MS 21.xx MA steel tape scale on aluminum carrier, **MS 21.xx MS** steel tape scale on steel carrier, carrier bolted
 max. measuring length = 4340 mm max. measuring length = 3540 mm

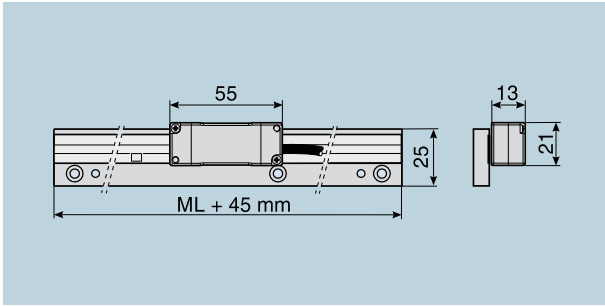

Dimensions, mounting tolerances, mounting possibilities:

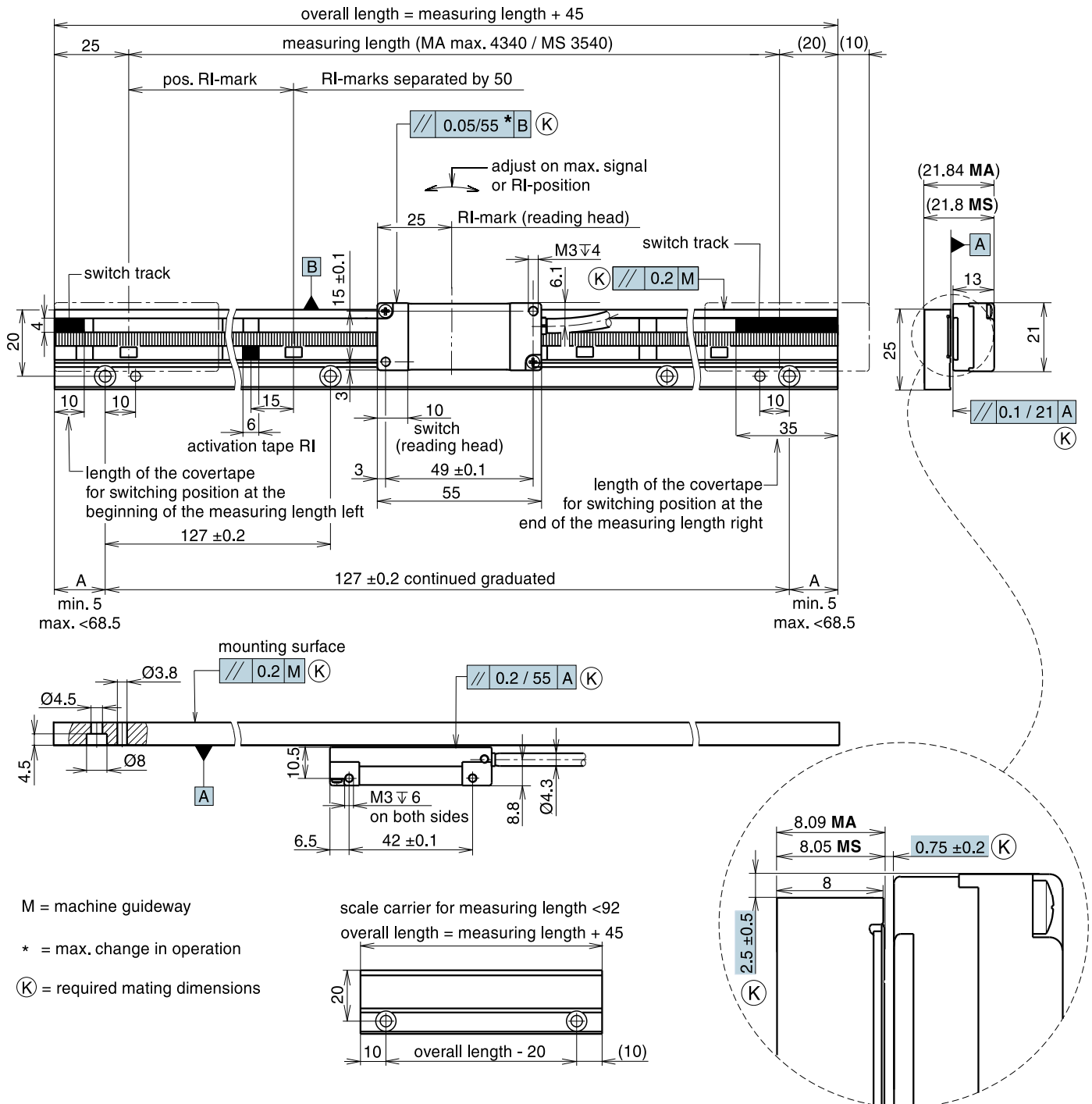

MS 21.xx GK glass scale with adhesive tape
max. measuring length = 3140 mm

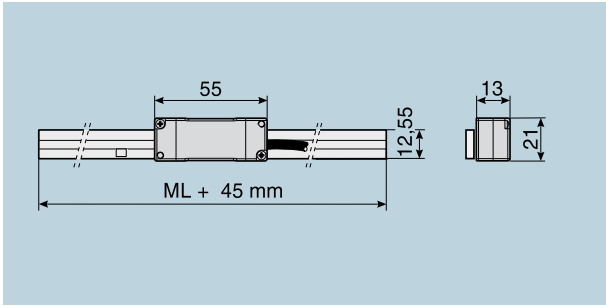

Dimensions, mounting tolerances, mounting possibilities:

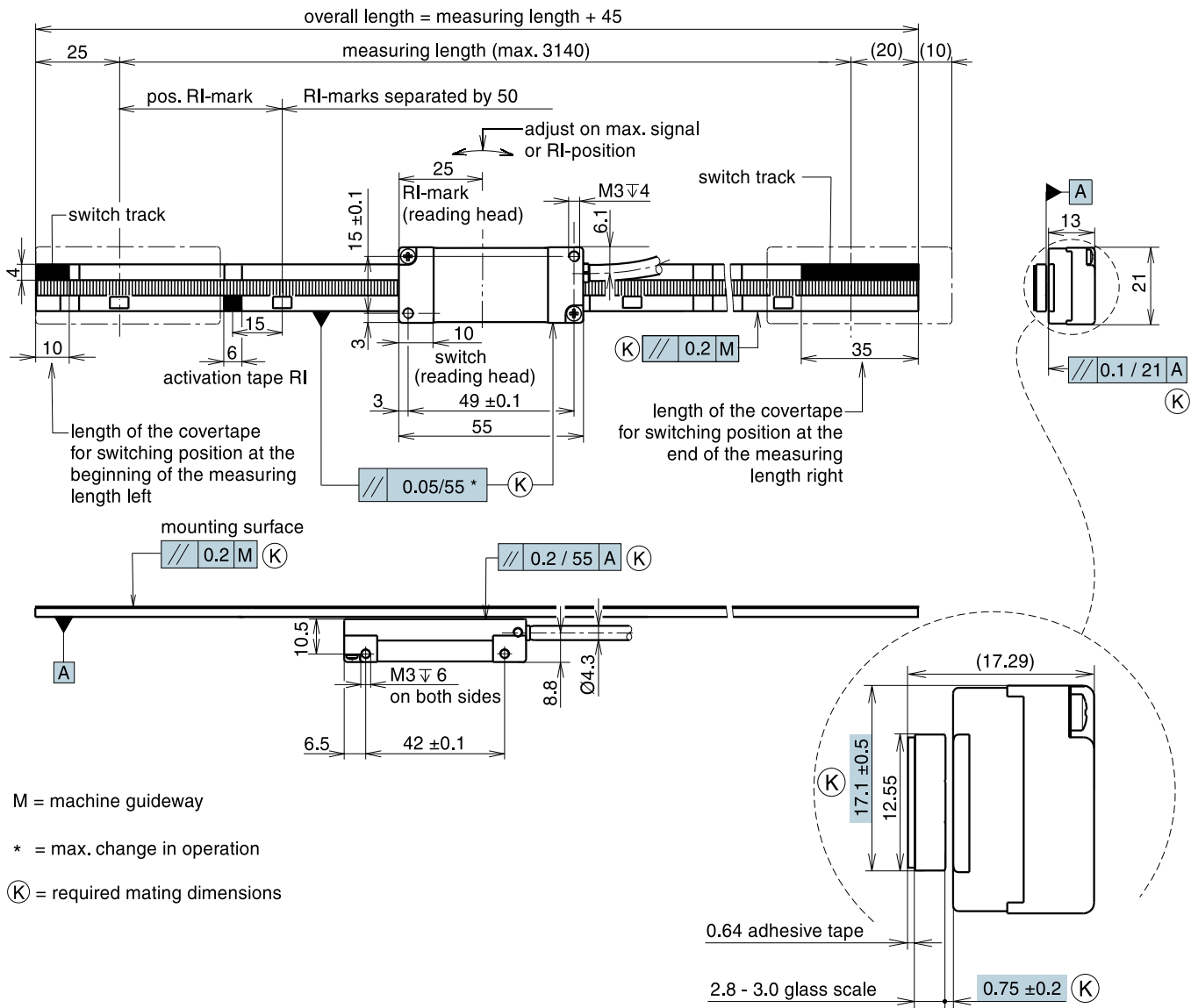

M = machine guideway

* = max. change in operation

(K) = required mating dimensions

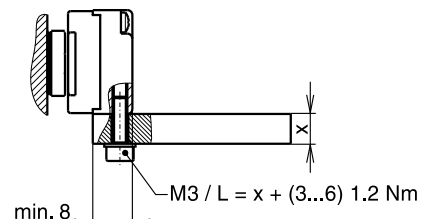
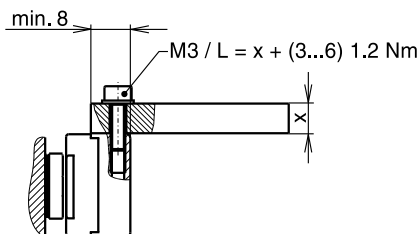
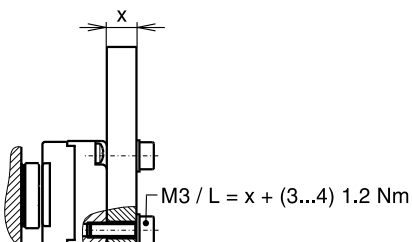

MS 21.xx GA glass scale on aluminum carrier, carrier bolted
max. measuring length = 3140 mm

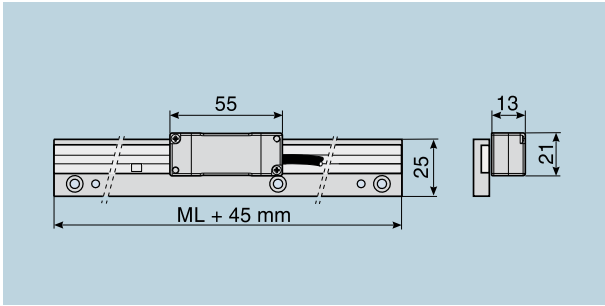

Dimensions, mounting tolerances, mounting possibilities:

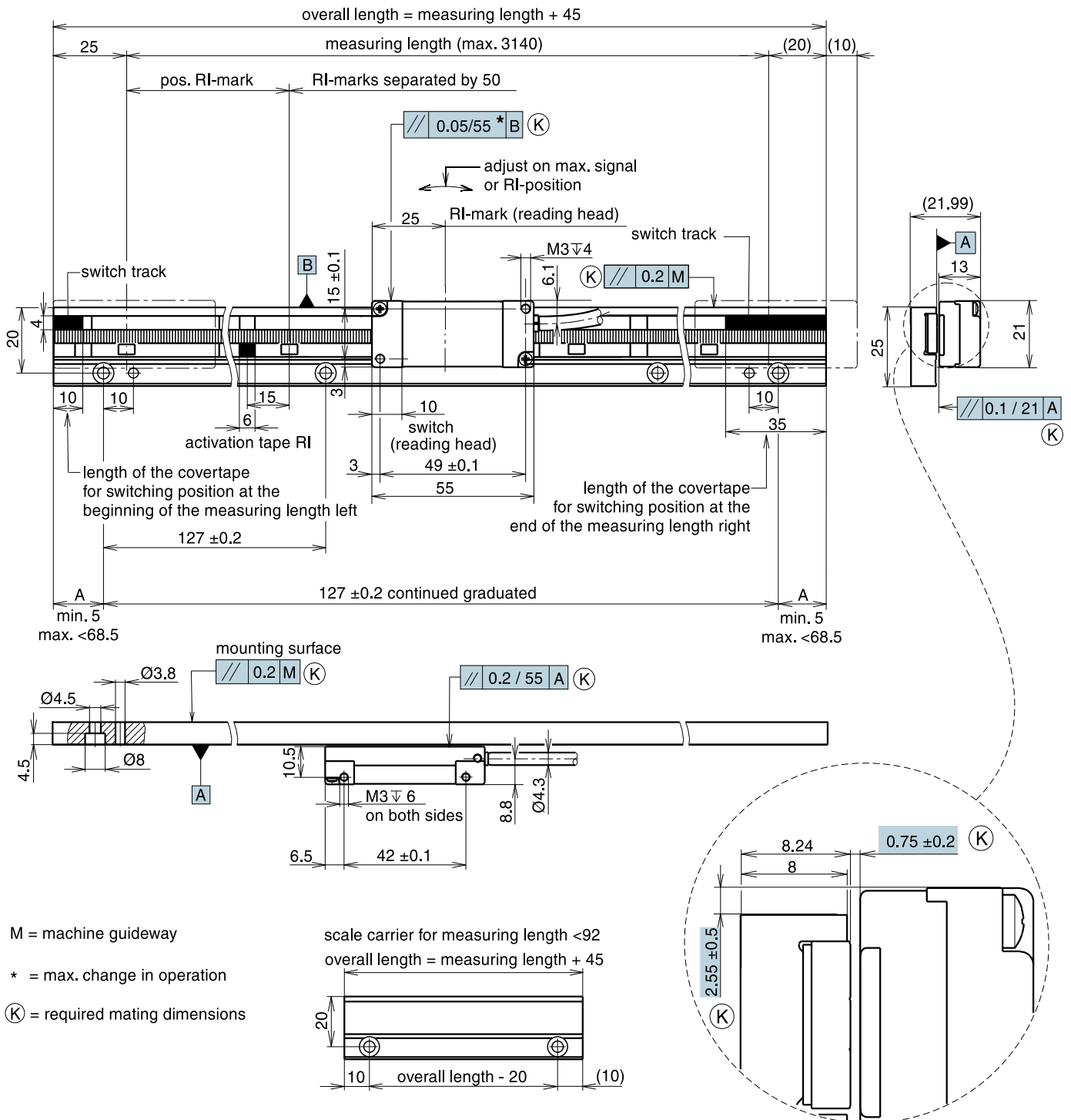

PG electronic signal test/set-up boxes

Open Linear Encoders are adjusted at the factory to provide optimal signals at the specified mounting conditions.

Even though the Linear Encoders in the MS 2x series allow for large mechanical mounting tolerances, it is recommended to inspect the mounting by checking the quality of the output signals.

There are various methods of checking the quality of the output signals.

The signals can be connected to an oscilloscope and checked for conformity with signal specifications. This method requires effort, training and expensive test equipment (oscilloscope). Often one or all of these items are unavailable to the installing technician.

As an alternative to this method, RSF offers different signal test boxes. With these test boxes all encoder signals can be quickly and easily checked.

The **PG1-I / PG1-U** is an all-purpose signal test box where all the relevant signals are displayed on LCD Bars. The **PG1-I / PG1-U** allows the quantitative as well as the qualitative evaluation of the encoder signals.

The **PG2-I / PG-U** test box checks all relevant signals; amplitude, phase and offset, and displays the results in a **qualitative** format on a polychromatic LED display.

PG1-I / PG1-U



PG2-

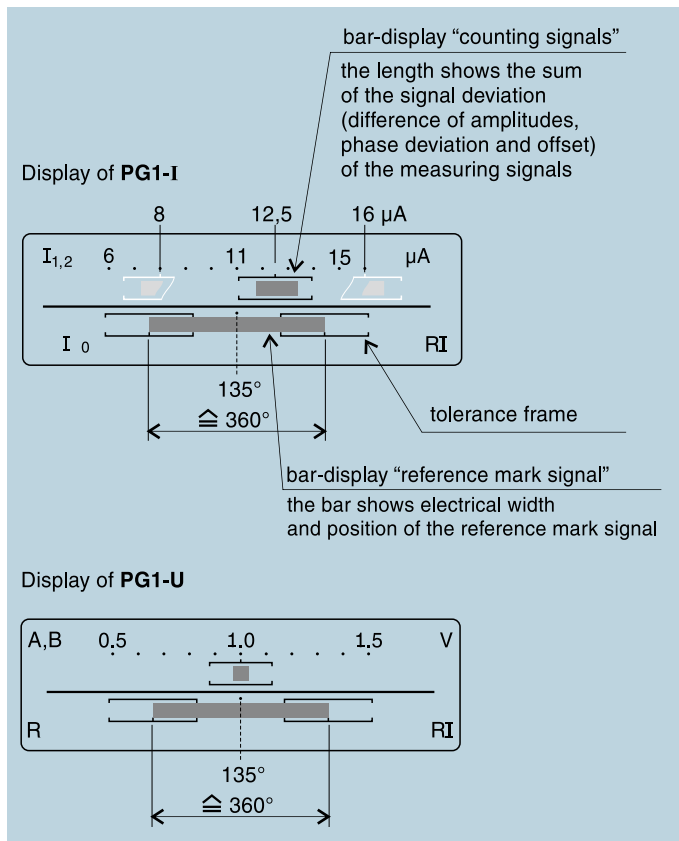

Intended PG-use	MS 20, MS 21 Output signals	
	square wave	sinus (1 V _{pp})
PG1-I	✓	--
PG1-U	--	✓
PG2-I	✓	--
PG-U	--	✓

Other RSF products, short description

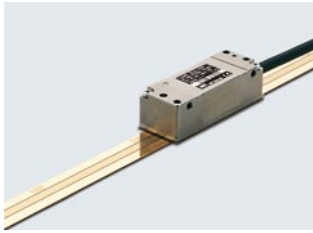

MS 30

Reflective scanning Linear Encoder

- small dimensions
- two independent switch signals for individual functions
- easy mounting as a result of large mounting tolerances
- high traversing speed
- high insensitivity to contamination
- integrated subdividing up to times 100 interpolation
- max. measuring length 9440 mm

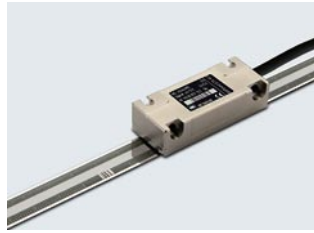

MS 40

Reflective scanning Linear Encoder

- with low price and high quality
- small dimensions
- easy mounting as a result of large mounting tolerances
- high traversing speed
- high insensitivity to contamination
- integrated subdividing up to times 100 interpolation
- measuring length unlimited

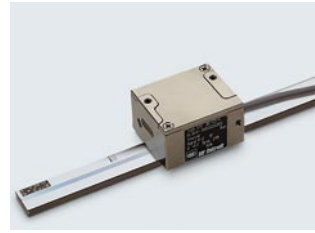

MS 8x

Interferential Linear Encoder

- two switch tracks for individual special functions
- non-contact reflective scanning
- for high displacement velocities
- small version
- scale version: glass scale or ROBAX glassceramic with phase grating
- max. measuring length to 3140 mm



TDE 60

Two dimensional Encoder

- non-contact reflective scanning
- small version
- scale version: glass scale
- measuring range 360 x 360 mm



MSA 170

- enclosed version
- guided by ball bearings
- distance coded RI marks (K)
- extremely small cross section
- mounting holes on the extrusion ends
- max. measuring length 520 mm

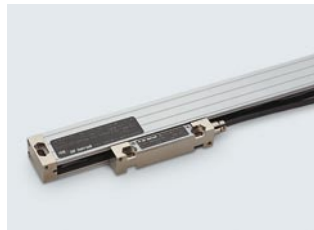

MSA 670

- enclosed version
- distance coded RI marks (K)
- small cross-section
- mounting holes on the extrusion ends
- max. measuring length 2240 mm



MSA 370

- enclosed version
- distance coded RI marks (K)
- large cross-section
- rigid mounting
- mounting holes on the extrusion ends and with mounting supports
- max. measuring length 3040 mm



Z 7x Reihe

Digital Readouts for universal application

- number of alphanumeric axis 1, 2 or 3 (depends on version)
- clearly readable display
- robust cast aluminum housing
- clear keyboard
- practice-oriented functions
- standard version for lathe or milling machine
- version for spark erosion machines and surface grinders on request

RSF Offices

Austria | RSF Elektronik Ges.m.b.H.
A-5121 Tarsdorf
☎ +43 (0) 6278 / 8192-0
FAX +43 (0) 6278 / 8192-79
e-mail: info@rsf.at
internet: www.rsf.at

USA | RSF Electronics Inc.
2880 Gold Tailings Court
Rancho Cordova, CA 95 670
☎ +1 916 852 - 6660
FAX +1 916 852 - 6664
e-mail: support@rsf.net
internet: www.rsf.net

Switzerland | RSF Elektronik (Schweiz) AG
Mülistrasse 18
CH-8320 Fehraltorf
☎ +41 (0) 44 955 10 50
FAX +41 (0) 44 955 10 51
e-mail: info@rsf.ch
internet: www.rsf.ch

China | RSF Elektronik GmbH
Tian Wei San Jie,
Area A, Beijing Tianzhu Airport Industrial Zone
Shunyi District
101312 Beijing
P.R. China
☎ +86-10-8042-0288
FAX +86-10-8042-0290
e-mail: cao.shizhi@rsf.cn
internet: www.rsf.cn

Slovenia | RSF Elektronik prodaja, d.o.o.
Jozeta Jame 14
SI-1210 Ljubljana
☎ +386 1 519 88 80
FAX +386 1 519 88 80
e-mail: mail@rsf-elektronik.si

Korea | RSF Electronics Ltd.
202 Namsung Plaza, 9th Ace Techno Tower,
345-30, Gasan-Dong, Geumcheon-Gu,
Seoul, Korea 153-782
☎ +82-2-2028-7455
FAX +82-2-2028-7456
e-mail: rsf@rsf.co.kr
internet: www.rsf.co.kr

Date 11/2008 • Art.Nr. 574898-23 • Techn. adjustment in reserve!



RSF Elektronik

Ges.m.b.H.

Precision Linear Scales
Digital Readouts
Industrial Electronics
Precision Graduations

certified according to
DIN EN ISO 9001
DIN EN ISO 14001

✉ **A-5121 Tarsdorf** • ☎ +43 (0)6278 / 8192-0 • FAX +43 (0)6278 / 8192-79 • e-mail: info@rsf.at • internet: www.rsf.at